

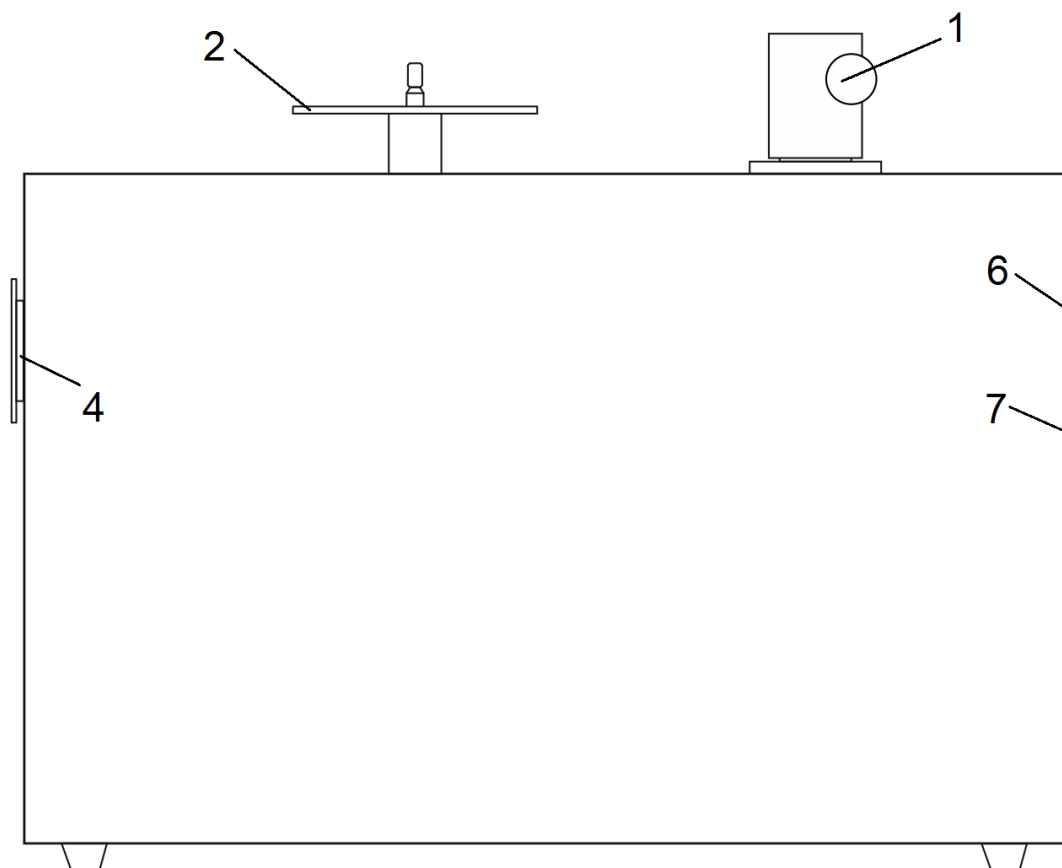

INSTRUCTIONS FOR USE
Project VC-S

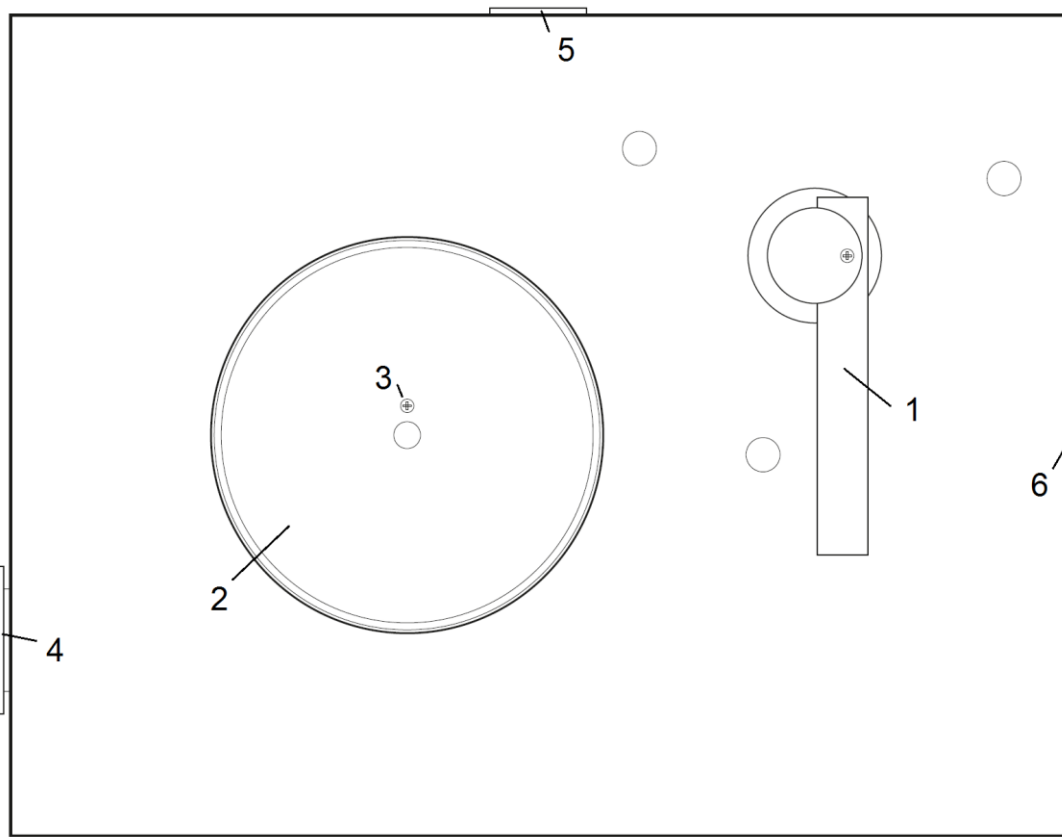

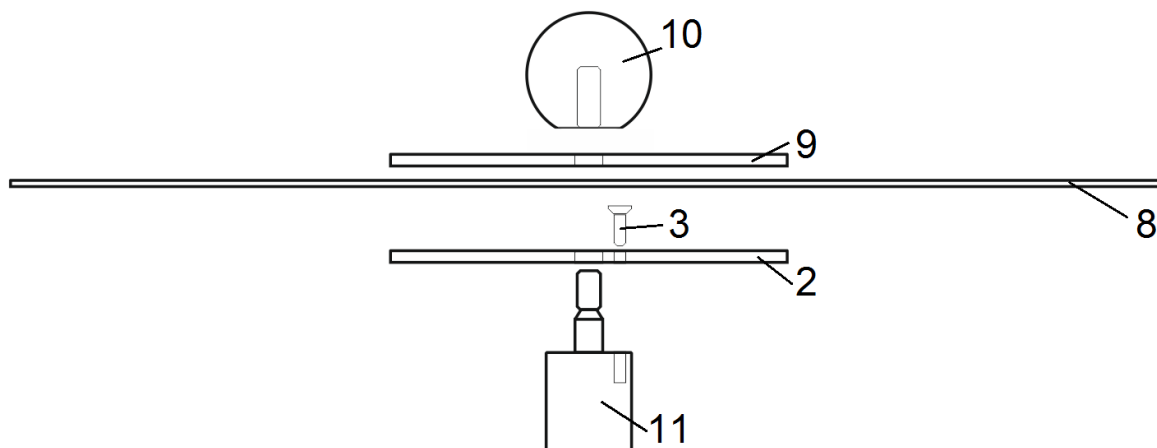

Pro-Ject VC-S

Controls, features and connections

- | | |
|----|---|
| 1 | Vacuum arm* (adhesive velvet strips attached) |
| 2 | Clamp (rear part)* |
| 3 | Fixing screw for clamp* |
| 4 | Ventilation outlet hole |
| 5 | Main switch with mains inlet socket |
| 6 | Vacuum rocker switch |
| 7 | Motor rocker switch |
| 8 | Vinyl record |
| 9 | Clamp (top part)* |
| 10 | Ball knob* |
| 11 | Spindle |

Accessories (delivered, but not shown above)

- | | |
|---|--|
| 1 | Wash it vinyl cleaning concentrate (100ml bottle) |
| 2 | Goat hair brush |
| 3 | Adhesive strips for vacuum arm (replacement) |
| 4 | Spout (drain insert) |
| 5 | Mains connection cable |

Optional accessories (available on request)

- **Wash it** vinyl cleaning concentrate
bottle sizes: 100ml/250ml/500ml/1l (100ml \approx 150 records / both sides)
- **Wash it 78** shellac cleaner concentrate (without alcohol)
bottle sizes: 250ml/ 1l (100ml \approx 150 records / both sides),
- Goat hair brush
- Adhesive strips for vacuum arm
- Cover it VC-S (lid with hinges and mounting screws)

Dear music lover,

Thank you for purchasing a Pro-Ject Audio Systems record cleaning machine.

In order to achieve maximum performance and reliability, please study these instructions carefully.



Warning of a hazard for the user, the unit or possible misuse



Important notice

During assembling and adjustment small parts could be lost if they are not carefully placed in a suitable receptacle. Before starting assembly make yourself acquainted with the parts listed above which are correspondingly numbered in the technical drawings. Separately packed items are marked with an asterisk *.

Safety instructions

AC outlet voltages vary from country to country. Before connecting to the mains, make sure that the voltage in your area meets the voltage requirements printed on the device.

Hold the plug when unplugging the power cord. Never handle the power cord while your hands are wet or damp.



Never place any naked flame sources, like lighted candles, on or near the device. The product shall not be used in damp or wet locations, next to a bathtub, sink, swimming pool or any other similar conditions.

Keep plastic bags away from children to prevent any risk of suffocation.

Do not cover any ventilation holes (one is located on the left side and others are on bottom).

Setting up the unit

The unit is supplied assembled except of platter and vacuum arm which are packed separately. Remove all parts from the transport packaging carefully. Please see the picture above that shows how to assemble the unit (screwdriver is required).

Preparation of Wash it vinyl cleaning fluid

The cleaning concentrate should be diluted before application:



Mix 1 part of Wash it concentrate with 5 parts of distilled / demineralized water!



Caution! The vinyl cleaning concentrate is only suitable for vinyl records. 78rpm shellac records are sensitive to some cleaning agents, please only use special Wash it 78 cleaning fluid!

Preparation of Wash it 78 shellac cleaning fluid

The cleaning concentrate should be diluted before application:



Please follow instructions delivered with Wash it 78

Using the unit

Make sure the unit is fully set up following the article above in this manual. All 3 rocker switches ("main switch", "motor" and "vacuum" should be in position "0"). Connect the power cord to the socket on the back side and turn the main switch to the position "I".

Place a record on the rear part of the clamp, put the top part of the clamp on it and screw it all together with the ball knob by using a moderate force. Do not over-tighten. If the force is too low, the record will not turn even if the motor runs.

Apply a few drops of cleaning fluid and spread it over the surface of a record using the supplied brush. The fluid should be evenly spread out over the entire surface. Use only the necessary amount of fluid, just to cover the record, not the machine!

The record label is protected by the clamp. The motor can turn both directions or can be stopped during the application of the fluid, depending on your personal preferences. For better dissolving of impurities, wait a few seconds before starting the vacuuming process. Place the vacuum arm above the record pointing at the spindle until it reaches its lock position. Turn the motor rocker switch into position "I" for rotating clockwise or to position "II" for counter-clockwise rotation and then turn on the vacuum rocker switch. Usually one revolution of the record is needed for full fluid removal.

Switch off vacuum first and then the motor. Return the vacuum arm into its rest position and wait a few seconds. Unscrew the ball knob, remove the clamp, turn the record over and repeat the steps for the opposite side of the record.



The unit is protected by an automatic overheating protection, which switches the motor off in case of excessive usage. After a cool-down period, the unit returns to full usability!

Maintenance and cleaning

Your record cleaning machine requires little or no regular maintenance.

On the left side of the unit below the air outlet hole is a water level gauge. The tank inside has big capacity and it usually takes long time to fill the tank. Certain amount of cleaning fluid is also evaporized. In case of the water level reaching the point marked " ←MAX" the tank should be discharged:

1. remove the plastic from the ventilation outlet hole (4)
2. place the spout into the hole (this drain insert is supplied in the accessory box)
3. lift the opposite side of the unit up and empty the unit reservoir

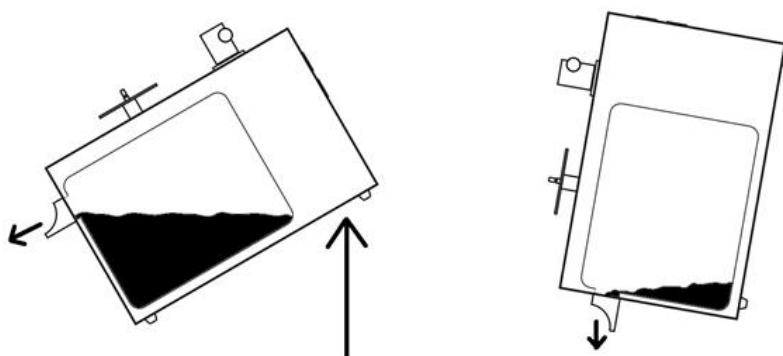

Regularly check the velvet strips on the arm. Make sure they are clean, no dirt or debris is present.



Always disconnect the record cleaning machine from the mains power supply as a precaution before maintenance!

Fitting the lid (Cover it VC-S is an optional accessory)

The holes for lid hinges are pre-drilled on the back side of the unit. Each hinge is screwed with 2 screws (supplied with the lid).

Fit the lid carefully over the hinge prongs and adjust the screws until the lid stays open where you want it to without being too stiff to open or close.

Technical specifications Vinyl Cleaner VC-S

Nominal speed	30 r.p.m.
Power consumption	230V/800W, 120V/1300W
Dimensions (W x D x H)	435 x 335 x 280 mm (fully assembled)
Weight	10,5kg (netto)
Fuse 230V/120V	T5A/T6A

Potential incorrect use and fault conditions

Pro-Ject products are manufactured to the highest standards and undergo strict quality controls before leaving the factory. Faults that may possibly occur are not necessarily due to material or production faults but can sometimes be caused by incorrect use or unfortunate circumstances. Therefore the following list of common fault symptoms is included.

The platter doesn't turn although the unit is switched on:

- The unit is not connected to the mains power supply.
- No mains at the socket.
- Broken fuse in the main switch.
- Overheating protection is active.
- Ball knob is not well-tightened.

Service

Should you encounter a problem which you are not able to alleviate or identify despite the above information, please contact your dealer for further advice. Only when the problem cannot be resolved there should the unit be sent to the responsible distributor in your country.

Guarantee repairs will only be affected if the unit is returned correctly packaged. For this reason we recommend keeping the original packaging.

Never return a record cleaning machine without making sure that it is safely disassembled and correctly packaged in the original packaging.

Warranty



The manufacturer accepts no responsibility for damage caused by not adhering to these instructions for use and/or by transportation without the original packaging. Modification or change to any part of the product by unauthorized persons, release the manufacturer from any liability over and above the lawful rights of the customer.

Pro-Ject Audio Systems is a Registered Trademark of H. Lichtenegger.

This guide was produced by: Pro-Ject Audio Systems
Copyright © 2015. All rights reserved.

The information was correct at the time of going to press. The manufacturer reserves the right to make changes to the technical specification without prior notice as deemed necessary to uphold the ongoing process of technical development.