



User Manual and Product Specifications

Safety Information

IMPORTANT INFORMATION - PLEASE READ CAREFULLY



This symbol indicates that there are important operating and maintenance instructions in the literature accompanying this unit.



This symbol indicates that dangerous voltage constituting a risk of electric shock is present within this unit.

Warning: The AC Input connector is used as a safety disconnect device. It must be easily accessible after installation.



This equipment is a Class II or double insulated electrical appliance. It has been designed in such a way that it does not require a safety connection to electrical earth.



Correct disposal of this product:

This marking indicates that this product should not be disposed of with other household wastes throughout the EU. To prevent possible harm to the environment or human health from uncontrolled waste disposal, recycle it responsibly to promote the sustainable reuse of material resources. To return your used device, please use the return and collection systems or contact the retailer where the product was purchased. They can take this product for environmentally safe recycling.

**Read and keep these instructions.
Heed all warnings and follow all instructions.**

Do not use this apparatus near water.
Clean only with a dry soft cloth.
Do not block any ventilation openings.
Install in accordance with the manufacturer's instructions.

Warnings:

To avoid the danger of suffocation, keep all polythene bags and packaging away from babies and children.

To reduce the risk of fire or electrical shock, do not expose this product to rain or moisture. This product must not be exposed to dripping and splashing and no object filled with liquids such as a vase of flowers should be placed on the unit.

Do not install near any heat sources such as radiators, heat registers, stoves, or other apparatus (including amplifiers) that produce heat.

Do not defeat the safety purpose of the polarized or grounding type plug. A polarized plug has two blades with one wider than the other. A grounding type plug has two blades and a third grounding prong. The wider blade or the third prong are provided for your safety. If the provided plug does not fit into your outlet, consult an electrician for replacement of the obsolete outlet.

Take note of all warnings on the appliance, under no circumstances disassemble the unit or remove covers to prevent the risk of fire or electrical shock.

Protect the mains power cord from being walked on or pinched, particularly at plugs, convenience receptacles, and the point where they exit from the apparatus.

Use only attachments/accessories specified by the manufacturer.

Unplug this unit during lightning storms or when unused for long periods of time.

No naked flame sources such as candles should be placed on the product.

Caution:

Changes or modifications not expressly approved by the manufacturer could void the user's authority to operate this device.

Third parties: In the unlikely event that you pass this product on to a third party, include these operating instructions with the product.

Service:

Refer all servicing to qualified service personnel. Servicing is required when the unit has been damaged in any way, such as the power supply cord or plug is damaged, liquid has been spilled on or objects have fallen into the unit, the apparatus has been exposed to rain or moisture, it does not operate normally or it has been dropped.

Equipment for servicing should be returned to the supplying dealer, or to the service agent for your area. The address of the main Service Agent for the UK is listed at the back of this manual.

Important notice for UK users:

The UK mains lead is terminated with a UK approved mains plug fitted with a 3A fuse. If the fuse needs to be replaced, an ASTA or BSI approved BS1362 fuse rated at 3A must be used.

Introduction

Thank you for purchasing Q Acoustics.

This manual is intended to take you through the setup and installation of the unit and will help provide a trouble free setup and optimum performance from the product.

Please read the instructions, important safety information and warnings carefully before installation and use, to ensure the safe and satisfactory operation of this product.

We hope you enjoy the Q Acoustics experience.

Package Contents

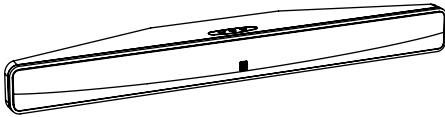

1 x Q M4 Hi-Fi Soundbar

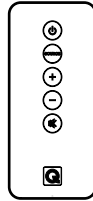

1 x Remote Control



1 x Lithium Battery (3V, CR2025)



1 x RCA Phono Lead (2 metres)



1 x 3.5mm Jack Lead (2 metres)



1 x Optical Lead (2 metres)

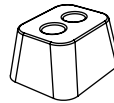

3 x Anti-vibration Feet with 6 x Screws

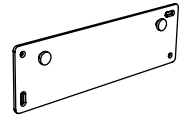

1 x Wall Mounting Plate

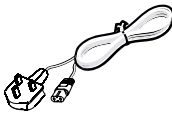

1 x UK AC Mains Cable

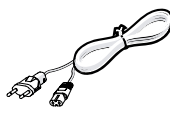

1 x EU AC Mains Cable

or

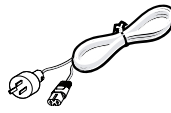

1 x AS/NZS AC Mains Cable



1 x User Manual

Features



Feature Summary

- 100W (2 x 25W + 50W) 2.1 amplification
- Built-in twin coil 100mm x 150mm subwoofer
- Wide dispersion 65mm x 65mm BMR drivers
- aptX® *Bluetooth* input – up to 8 paired devices
- Digital optical audio input
- RCA stereo line level audio input
- 3.5mm stereo headphone level audio input
- RCA subwoofer line level audio output
- 5 button infrared remote control



Product Description

The Q Acoustics Q M4 is a high performance soundbar designed to deliver high fidelity reproduction of music, and high quality audio from a TV or set top box, tablets and smartphones. Designed in the UK by Q Acoustics, is a result of careful development and our award winning heritage.

Q Acoustics provides true audio with no added effects or digital signal processing to colour audio reproduction. You have peace of mind that you are listening to pure audio as the original mix engineer intended.

Designed for simplicity, this product will blend into your home environment with minimal fuss yet extraordinary improvement to your listening experience.

With both analogue and optical inputs the unit can be used with a variety of entertainment sources such as TVs, CD players, portable music players, computers and internet radio.

The unit is also *Bluetooth* compatible using aptX Lossless for audio streaming. This wireless connection can sync to almost any *Bluetooth* compatible audio device. It can remember up to eight pairings, so when friends or family come over, a 'guest' music player can get connected in just seconds.

Please read and follow the instructions in this manual to get the most enjoyment out of your Q Acoustics.

Wall Mount

1.

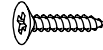
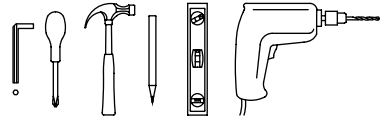
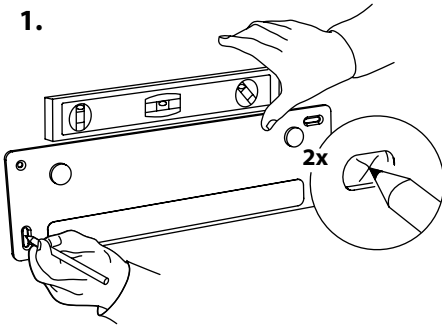

4 x 3mm Countersunk
Screws and Wall Fixing not included

2.

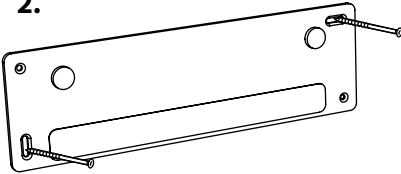

3.

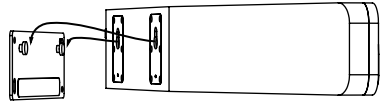

4.

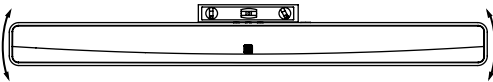

5.

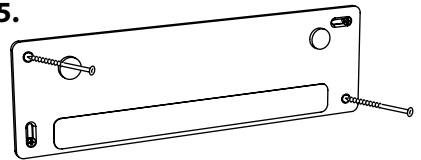

Feet Fixing

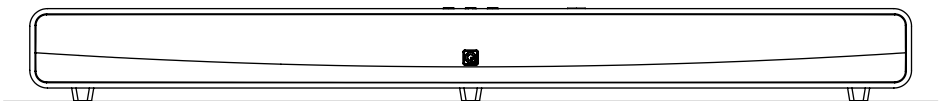
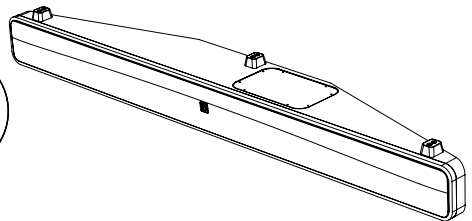
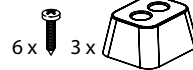
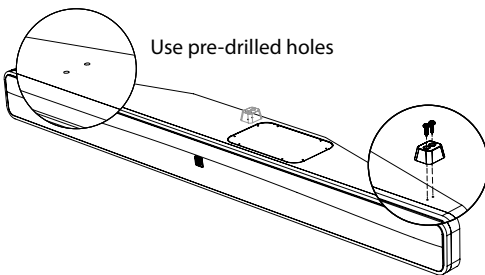

Instructions

Features

TOP PANEL

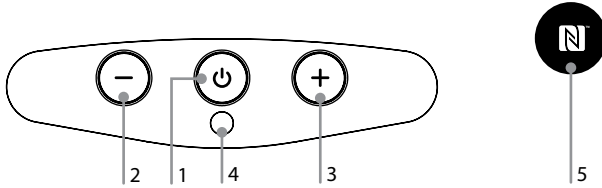

1. Standby / Source Select

Long press / short press

2. Volume Down

Single press / press and hold

3. Volume Up

Single press / press and hold

4. Status LED

See LED indications below

5. NFC Pairing Position

No Light = Off

Power cord is connected but AC switch is turned OFF, or power cord is disconnected.

Solid Red = Off (Standby)

Power cord is connected and AC switch is turned ON, but the unit is OFF.

Solid Green = On

Analogue input (Line in 1 or Line in 2) is the active source.

Solid White = On

Optical input is the active source.

Quick Blue Flash = On

Bluetooth input is the active source and is currently searching for a Bluetooth device to PAIR with.

Solid Blue = On

Bluetooth input is the active source and is PAIRED with a Bluetooth device.

Any Colour Slow Flash = On

Currently active source is MUTED.

FRONT VIEW

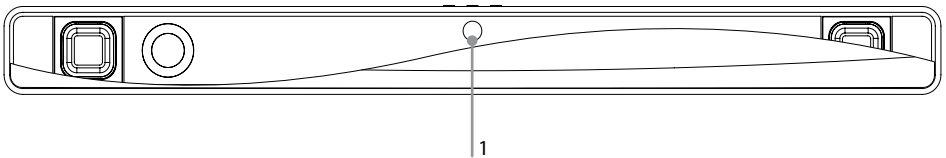

1. IR Sensor

The IR sensor is hidden behind the speaker grill in the centre towards the top of the unit.

This sensor MUST be unobstructed for direct line-of-sight to the remote, or the remote will not be able to control the unit.

REAR PANEL

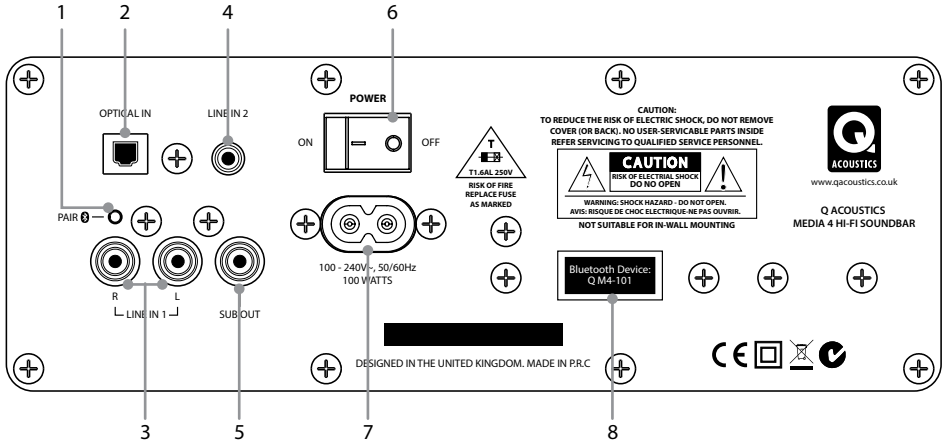

1. **Bluetooth Pair Button**
2. **Digital Optical Input**
3. **Analogue Line In 1**
4. **Analogue Line In 2**

5. **Subwoofer Out**
6. **Power Switch**
7. **AC Input**
8. **Bluetooth Name Label**

Instructions

1. Digital Optical Input

TOSLINK connector for connection to the Digital Optical output on a TV or other source. If there is a choice between Digital or Analogue connection to the unit choose Digital for superior audio quality. The Digital input is selected automatically if no *Bluetooth* device is connected and playing. When the Digital Source is active the status LED will be WHITE.

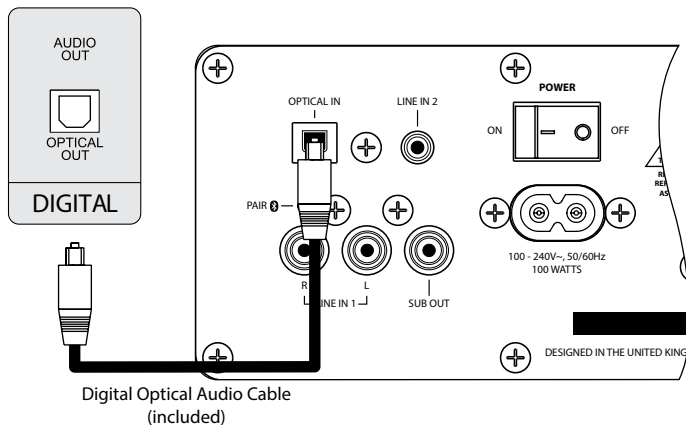

Important Note:

Audio output of a TV, Blu-ray disc player, games console, or DVD player connected to the unit via Optical Digital, must be set to PCM (two channel stereo) in the source's setup. Please see the device's Owner's Manual for details. Digital connection to a CD player does not require a special setting.

2 & 3. Analogue Inputs Line In 1 & Line In 2

The unit has two options for Analogue Audio connection:

Line In 1

Connect the RCA L&R audio output from a TV or other source to the LINE IN 1 sockets using the 2m cable provided:

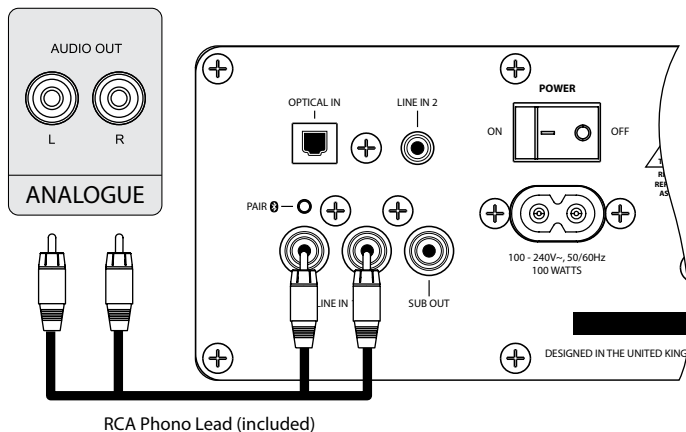

Line In 2

The 3.5mm input jack is ideal for connecting to the headphone output of an external audio source using the 2m cable provided:

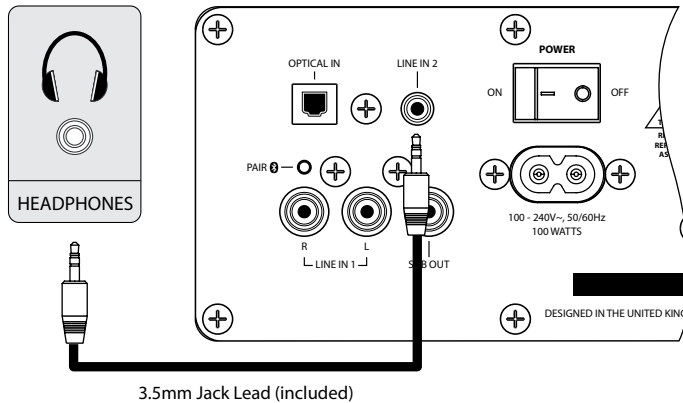

Important Note:

With a jack plugged into LINE IN 2, LINE IN 1 is switched-off and no audio will be heard from this source.

The ANALOGUE INPUTS are automatically selected when no *Bluetooth* device is connected and playing, and no Optical Digital Input signal is present. The Status LED will be GREEN when an analogue input is in use.

Please Note:

When connecting to a variable level source, such as a headphone output, better audio quality will be achieved by having the source set at a higher volume level and the unit at a lower level than the other way around.

4. Subwoofer Out

Single RCA phono jack. Connect the 'Sub Out' to a Subwoofer Line Level Input if extended bass response is desired.

5. Bluetooth Pair Button

The unit has been designed to automatically search for, and PAIR with a device should no other devices currently be PAIRED and in range. This *Bluetooth* Pair button is used to manually drop the current connection and pair with a new device.

6. Power Switch

Turns the power to the unit ON/OFF.

Important Note:

Always turn the power OFF when making connections to the Rear Panel.

7. AC Input

Universal power connector. Automatically selects AC voltage for a given region. Connect to the included AV Power Cord for your country.

Instructions

Remote Control

1. Power

Press this button to turn the unit Standby ON/OFF. (POWER SWITCH on the rear panel must be switched to ON)

2. Source Select

Press this button to manually select the audio input source. The status LED will change colour accordingly.

Important Note:

When the Source button is used, the unit will stay on the selected source and stop auto-source selection. Auto-source selection will be resumed after the unit has been put in standby.

3. Volume Up / Down

Press VOL + to increase the volume. Press VOL - to reduce the volume.

4. Mute

Press this button once to MUTE the unit (no audio output from the speakers). Status LED will SLOW FLASH to indicate MUTE. Press this button again to un-mute the unit (audio output from the speakers).

Please Note:

Long press of Mute will also put the unit into standby.

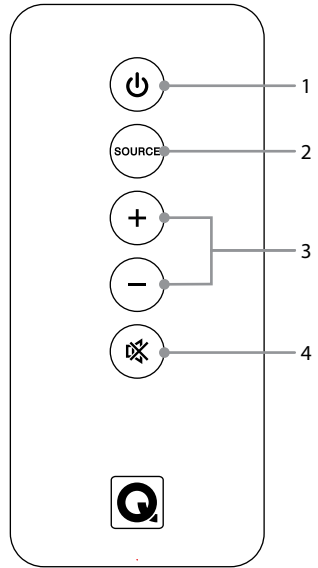

REMOTE CONTROL BATTERY REPLACEMENT

Caution:

When replacing the lithium battery in the remote, make sure that the replacement battery is inserted in correct polarity. Place the battery so that its positive (+) side faces up with the tray held so the surface with the dot and (+) is facing up.

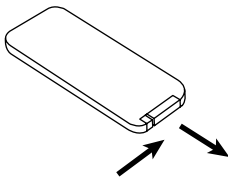

1. Push small tab toward battery slot.

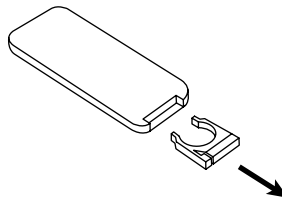

2. Pull battery drawer out.

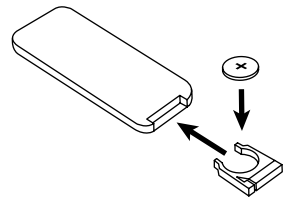

3. Insert battery with "+" side up and slide drawer back into remote.

Caution:

Danger of explosion if battery is incorrectly replaced. Replace only with the same or equivalent battery type (CR2025)

Warning:

Do not expose batteries to excessive heat such as direct sunlight, fire or the like. Dispose of dead batteries in accordance with local regulations.



Operating Q M4

POWER AND STANDBY

Power on the unit at the AC SWITCH once all rear panel audio connections are made. The speakers will enter STANDBY, with a RED status LED.

Exit STANDBY by pressing the STANDBY button on either the top panel or the IR remote. The LED will initially turn Green but may then change according to the Auto-Source Selection rules.

If NO input signals are detected, the unit will automatically enter STANDBY after 20 minutes.

AUTO-ON FUNCTION

When connected to an optical source, the unit has an AUTO-ON function and will come out of standby when it detects that an optical signal is present. This allows easy integration of the unit with your television, automatically turning on when you bring your TV out of standby.

Please Note:

If you place the unit in standby while an optical source is still present, the auto-on function will be disabled until the optical source is turned off. This will prevent the unit from unwanted auto-on.

Please Note:

Some televisions continue their optical output when the TV is in standby. The unit will not auto-standby under these circumstances and the standby control must be used.

AUTO-SOURCE SELECTION

In normal operation the unit will automatically select the audio source. A connected *Bluetooth* source that starts to play has the highest priority, followed by Digital and finally Analogue:

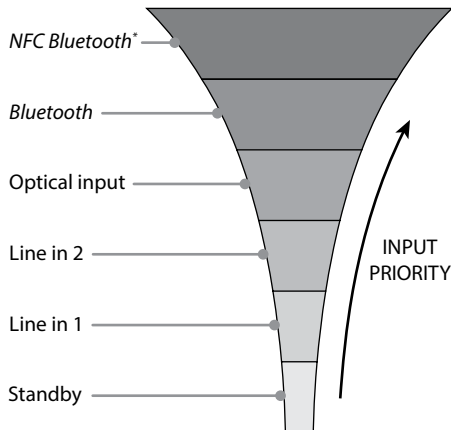

**A Bluetooth device connected via NFC will take priority over all other sources.*

The Auto-Source Selection can be manually overridden at any time using SOURCE SELECT on the IR remote or by a short press of the button on the unit.

Important Note:

The unit will stop using Auto-Source Selection when the source is manually selected using the Source Select button on the remote, or a short press of the Standby Button on the unit. Auto-Source Select will resume once the unit has been put into and out of Standby.

Instructions

SOURCE VOLUME CONTROL

Audio sources will initially be set at a DEFAULT volume level. The volume can be adjusted separately for each source using the VOL + and VOL – buttons on the top panel or IR remote. Once adjusted, the unit will remember the new volume level for the currently selected source, and will return to that level each time that source is re-selected.

PAIRING A BLUETOOTH DEVICE

The unit is designed to automatically go into pairing mode if there is no *Bluetooth* device connected. To Pair your *Bluetooth* source:

1. Turn the unit and the *Bluetooth* device ON.
2. Make sure *Bluetooth* is enabled on the device to be Paired. The *Bluetooth* controls are typically found in the device's 'Settings' or 'Connections' menu.
3. On your device's list of discoverable devices, you should now see 'Q M4-XXX' where XXX is a pre-defined three digit number. (Refer to Rear Panel section for the *Bluetooth* name label.)
4. Select 'Q M4-XXX' and your device will now be Paired via *Bluetooth* and Connected.
5. From within the music player on your device, select 'Q M4-XXX' as the audio output and press Play. Unless the remote has been used to manually select another source and override Auto-Source Selection, the unit will switch to *Bluetooth* input and the LED will turn Blue.

PAIRING A BLUETOOTH DEVICE WITH NFC

1. Turn the unit and the Bluetooth NFC device ON.
2. Make sure Bluetooth and NFC are enabled in the device settings.

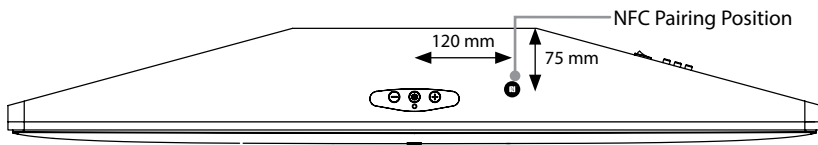

3. Place NFC device on the top surface of the unit, in the location indicated.

Please Note:

You may need to rotate your device for NFC to connect, as NFC coil is in different locations within different devices. Please see your device instruction manual for correct NFC operation. The distance for NFC pairing occurs vary from device to device.

4. The NFC device will automatically register on screen when an NFC connection has been made.
5. Follow on-screen instructions to complete NFC pairing. This usually involves selecting to allow NFC pairing.
6. Your device will now be paired, and connected via Bluetooth, and will function as any other Bluetooth source when pressing play from within the device music player.

Please Note:

Although starting to Play a track on the connected source will cause the unit to switch to *Bluetooth*, the unit will stay on *Bluetooth* until the source is disconnected. It will not switch to another source whilst the player is paused.

Please Note:

Auto-Source Selection will switch to *Bluetooth* the first time a connected device sends any audio signal including message received alerts and key press effects.

Please Note:

When connected, the device's volume and mute controls control the device itself, not the unit. Better audio quality will be achieved by having the device set at a higher volume level and the unit at a lower level.

GOING OUT OF RANGE

When a connected device goes out of range, the unit will remain on the Bluetooth channel. When the device returns in range it will automatically re-connect to the unit. In many cases PLAY must be pressed on the device to resume audio playback. Whilst out of range, source can still be changed using the SOURCE SELECT button.

Please Note:

If the source does not come back into range for 20 minutes the unit will automatically go into standby.

PAIRING MORE THAN ONE BLUETOOTH DEVICE

The unit can have up to eight *Bluetooth* devices in its pairing list. When you pair with the 9th device the details of the first device will be lost.

Once the unit is connected with a device, it will stop automatically searching for other devices to pair with or connect to. To connect to another device, either disconnect the currently connected source on the device itself or press the *Bluetooth* Pair button on the rear panel of the unit.

COMING OUT OF STANDBY

If there is a paired device in proximity to the unit when it comes out of standby it will automatically initiate a connection to the device. It will not switch to *Bluetooth* input until play is pressed on the device.

Instructions

CABLE/SATELLITE REMOTE CONTROL

The Q Acoustics system has been designed for easy integration into your home entertainment system as it has the ability to be controlled by many types of PROGRAMMABLE REMOTE CONTROL. This may include the remote control for your SATELLITE and CABLE system if it has PUNCH THROUGH capability. Punch through is the common term for being able to programme your remote control to send IR codes to both a TV and an AV Preamplifier/Processor. To use punch through you normally select the TV you wish to support first, and then the AV Preamplifier/Processor.

The unit uses the PHILIPS RC5 protocol for AV Preamplifiers/Processors. Programming your remote with PHILIPS AV codes should allow you to control volume and mute of your unit. In some cases you may also be able to control standby and source select with buttons such as ◀▶ ▶▶ ◀ and ▶▶.

Manufacturers often offer several PHILIPS code options for their remote controls. We recommend that you work through the PHILIPS code list for your remote and experiment with each one until you find one that works well with the unit. It is easiest to recognise when one is working by pressing the volume up/down buttons.

We cannot guarantee that the unit will work with your particular remote as the IR codes it sends are outside our control, however by supporting the commonly used Philips standard we hope to have made it as easy as possible to gain control of your device with the remote control of your choice.

Below we show how two typical programmable remote controls can be set up.

TYPE 1 (SATELLITE)

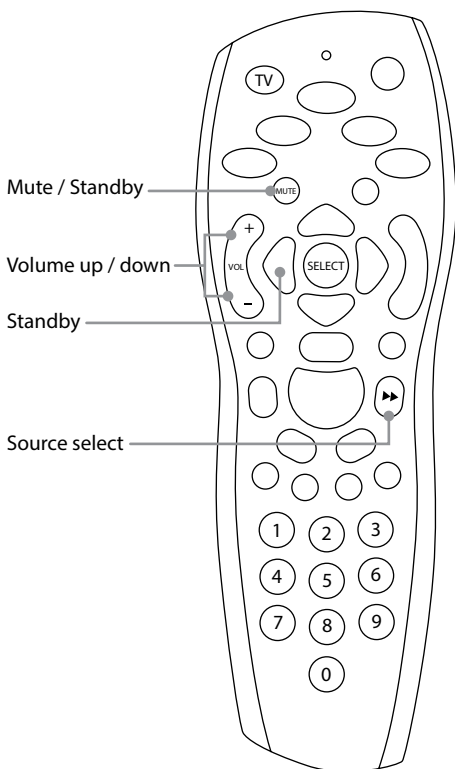

- Press the "TV" button (top left of remote).
- Point remote away from receiver, press and hold "Select + 0".
- The remote's LED will flash red twice.
- Enter "1217". The remote's LED will flash red twice to confirm correct code.
- Press and hold "Select + 1".
- The remote's LED will flash red twice.
- Press TV and your remote controls will now work as below:

Button	Function
Vol +	Volume up
Vol -	Volume down
Mute (short press)	Mute
◀ or Mute (long press)	Standby
▶▶	Source select

TYPE 2 (CABLE)

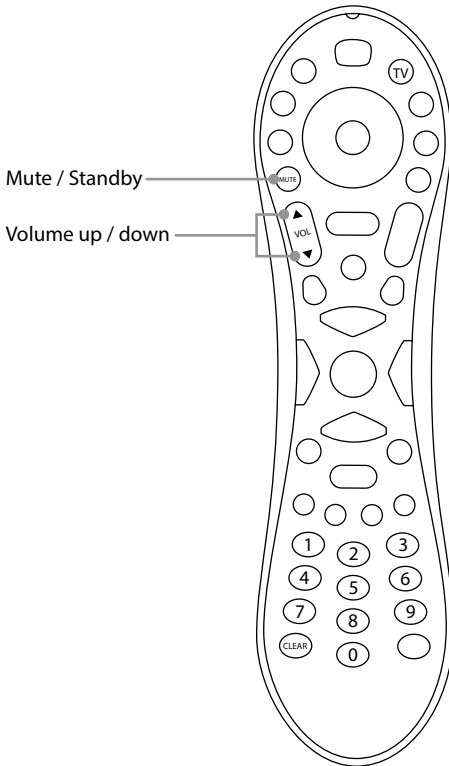

- Press the "TV" button (top right of remote).
- Point remote away from receiver, press and hold "Clear + Vol ▲".
- The remote's LED will flash green twice.
- Enter "1247". The remote's LED will flash green twice to confirm correct code.
- Press TV and your remote controls will now work as below:

Button	Function
Vol ▲	Volume up
Vol ▼	Volume down
Mute (short press)	Mute
Mute (long press)	Standby

Specification



Specification

Audio performance

Power output:	100W (2 x 25W + 50W) total amplification
THD (at rated power):	<1.00%
Frequency response:	±0.5dB 20Hz to 20kHz
S/N ratio (A-Wtd):	-85dB
Line in 1 (RCA phono) input sensitivity:	2.0Vrms
Line in 1 (RCA phono) input overload:	2.2Vrms
Line in 2 (3.5mm jack) input sensitivity:	1.0Vrms
Line in 2 (3.5mm jack) input overload:	1.2Vrms

Speakers

LR drivers:	BMR 65mm x 65mm
Subwoofer:	Twin coil 100mm x 150mm

Power consumption

Standby:	<0.5 Watts
No signal (idle):	14 Watts
Rear panel marked line ratings:	100~240V - 50~60Hz 100W

Bluetooth®

Bluetooth specification:	V4.0 class 2 device
Latency:	6ms
Internal stereo CODEC:	16-bit
Stereo audio sample rate:	up to 48kHz
Music enhancements:	aptX®, SBC, MP3
Support for:	A2DP, 802.11 co-existence

Dimensions

(W x H x D):	1000mm x 90mm x 142mm
Height including feet:	105mm

Weight

Total weight:	4.9 kg
---------------	--------



Q Acoustics Warranty

Q Acoustics products are warranted free of defects in materials and workmanship for a period of 2 years from the date of purchase. During the warranty period Q Acoustics will, at its option, repair or replace any product found to be faulty after inspection by the company or its appointed distributor or agent.

Misuse and fair wear and tear are not covered by warranty.

Goods for repair should in the first instance be returned to the supplying dealer. If this is not possible contact Q Acoustics or their appointed distributor for your area to determine the correct warranty procedure. If possible the original packaging should be used to return the product as damage sustained during transit to the repair centre is not covered by the warranty. The warranty does not in any way affect your legal rights.

For service information In other countries contact: info@qacoustics.co.uk

Q ACOUSTICS

Armour Home Electronics Ltd.
Stortford Hall Industrial Park
Bishops Stortford, Herts, UK
CM23 5GZ



The N-Mark logo is a registered trademarks of the NFC Forum Inc.



The *Bluetooth* word mark and logos are registered trademarks owned by Bluetooth SIG, Inc. and any use of such marks by Armour Home Electronics Ltd. is under license. The aptX® mark and the aptX logo are trade marks of CSR plc or one of its group companies and may be registered in one or more jurisdictions. Other trademarks and trade names are those of their respective owners.